

STORM BLOCKER

CATEGORY H

The Acrylic Block Window
Independently Tested in Accordance
with Miami-Dade County Florida
Hurricane Window Standards

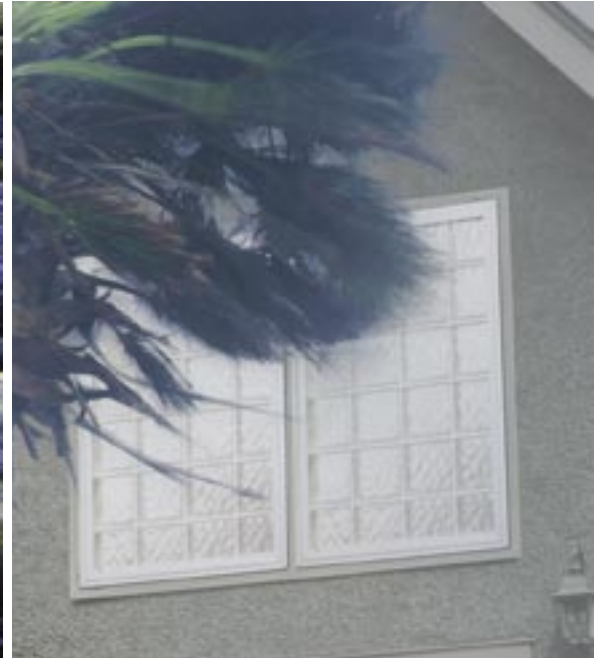

BRILLIANT IDEAS FOR HOME

Designed for Style and Privacy; Engineered to Weather the Storm

New Hy-Lite StormBlocker windows deliver style, privacy and easy installation while having been independently tested in accordance with all Miami-Dade County testing requirements. StormBlocker's proprietary Category H design technology withstands storm-force wind and rain, while providing high energy efficiency (U value .37). StormBlocker is the perfect solution for storm-prone areas during this highly active hurricane cycle, which U.S. hurricane experts predict will last another 10 to 20 years. What's more, StormBlocker's high-impact design provides additional home security.



See the Missile Impact Test Video Online!
www.hy-lite.com/hurricane

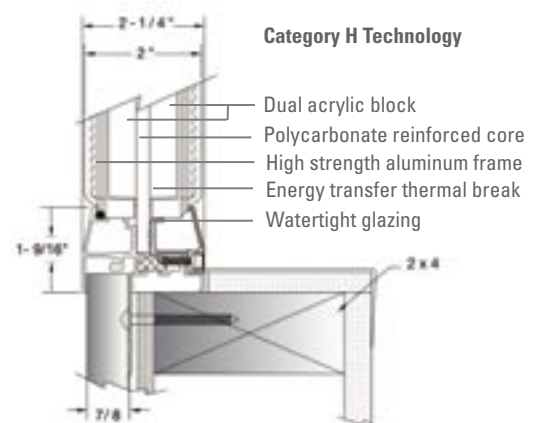

Hy-Lite
www.hy-lite.com

STORM BLOCKER

CATEGORY **H**

Hy-Lite StormBlocker windows have been independently tested in accordance with the testing requirements of Miami-Dade County: high impact, water leak and extreme internal/external pressure tests, as performed by an independent testing laboratory. StormBlocker achieved a 90 DP pressure rating, equivalent to a 230 mph wind speed (test performed on 50" x 90" window).

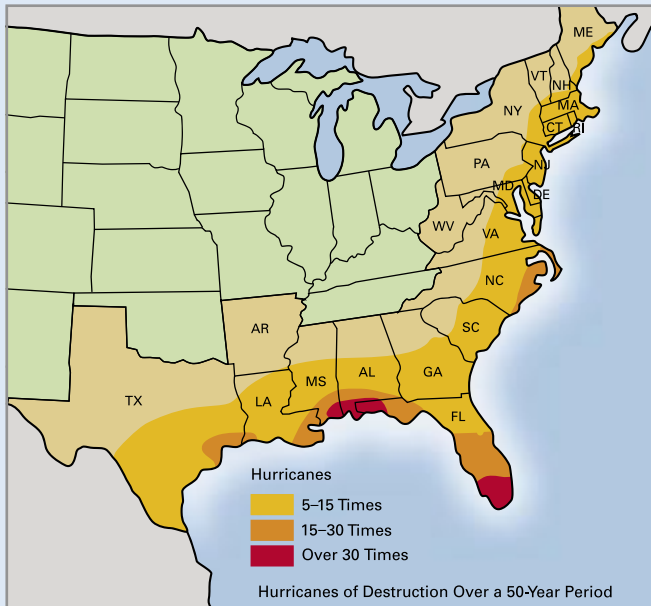

U.S. Tropical Storm Zone



Available Block Types & Window Sizes

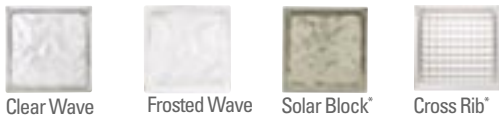

	Rough Opening W x H	Block Configuration
6" Blocks*	44" x 44"	7 x 7
	44" x 50"	7 x 8
	50" x 50"	8 x 8
8" Blocks	42" x 42"	5 x 5
	42" x 50"	5 x 6
	50" x 50"	6 x 6

*Allow 3-4 weeks for delivery



Hy-Lite Products Inc.
Corporate Headquarters
 1011 Park Lane
 Greensboro, GA 30642
 (800) 827-3691

Manufacturing Facility
 117 Sara Lee Drive
 Eatonton, GA 31024
 (800) 423-3032

www.hy-lite.com

South Florida Building Code (SFBC) Section 2315 Southern Florida Building Code Congress International, Inc. (SBCCI) SSTD Section 12

Impact Requirements

Specimens were impacted in accordance with Southern Florida Building Code (SFBC) requirements with Test Protocol TAS 201-94.

Cyclic Wind Loads Subsequent to impact testing, specimens were subject to cyclic loading in accordance with (SFBC) requirements Test Protocol TAS 203-94.

Wind Loads Specimens were independently tested using uniform static air pressure to SFBC Test Protocol TAS 202-94.

Air Infiltration Independently tested in accordance with ASTM E 331 @ 135 psf (includes 50% safety factor) static wind load with no measurable air infiltration.

Water Infiltration Independently tested in accordance with ASTM E 331 @ 135 psf (includes 50% safety factor) static wind load with no observable water infiltration. DP90 Pressure Rating AAMA/WDMA 101/I.S.2-97

SHGC .58

U Value .37